

# 아우터로터형 편흡직결 다익 송풍기 (AC)

## OUTER ROTOR SINGLE INLET DIRECT DRIVE CENTRIFUGAL FANS

### 제품 설명

- 전열 교환기 및 렌지 후드용 공기 이송장치, 전자장비·통신장비의 냉각용에 적합
- 휠 일체형으로 소형화 및 경량화 실현하여 협소한 장소에서의 설치 및 취급 용이
- 국제품질인증(CE마크) 획득을 통한 품질 확보
- 주파수와 관계없이 속도 제어 가능하며, 전식처리를 통한 제품 신뢰성 우수
- 풍량 대비 낮은 전기 소모량(고효율)으로 에너지 등급 우수



### 제품 제원

MODEL	정압		풍량		상세 페이지
	mmAq	Pa	m <sup>3</sup> /min	ft <sup>3</sup> /min	
AOS2S-120-60A	40	392	4.4	155	105p
AOS2S-133-60A	39	382	4.3	152	
AOS2S-145-60A	57	559	5.9	208	106p
AOS4S-145-60A	40	392	6.5	229	
AOS2S-160-60A	72	706	8.0	282	107p
AOS4S-160-60A	23	225	7.5	265	
AOS2S-180-75A	95	931	10.8	381	108p
AOS4S-180-75A	32	314	10.0	353	
AOS4S-180-90A	32	314	15.5	547	109p
AOS4S-200-100A	34	333	16.0	565	

• AOS2S-120-60A

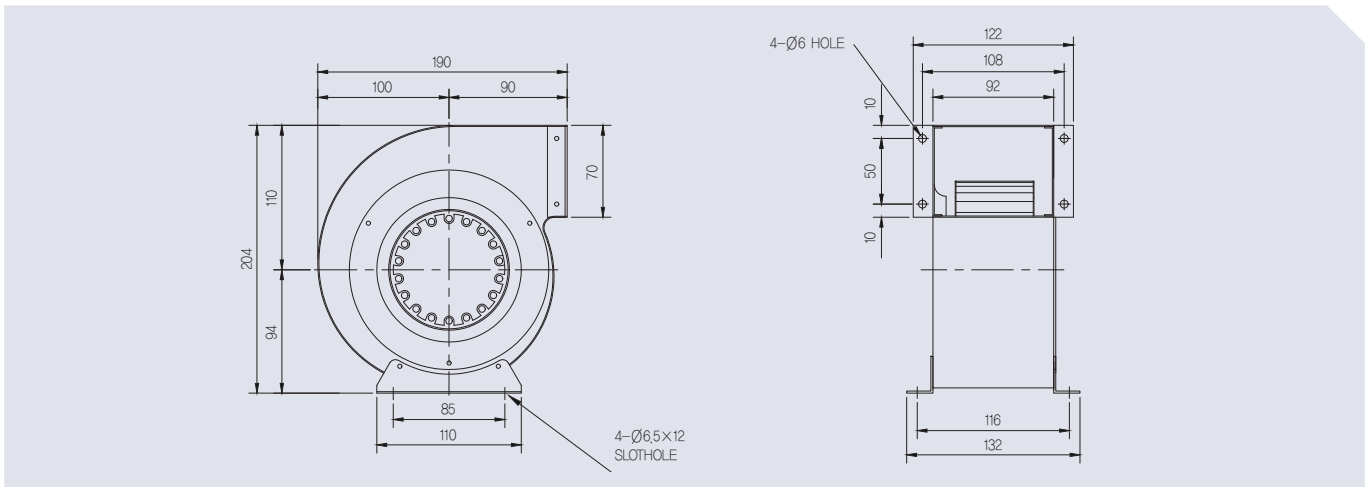

전 원			정압	풍량	소비전력	소비전류	회전속도
Phase	V	Hz	mmAq	CMM	W	A	RPM
φ 1	220	60Hz	40	4.4	100	0.46	1870
φ 1	220	50Hz	27	4.2	98	0.46	1870

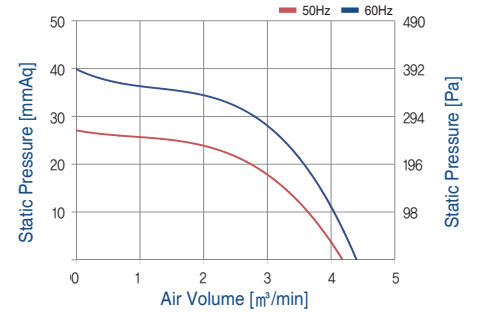

팬흡착결 다이 송풍기 (AC)

• AOS2S-133-60A

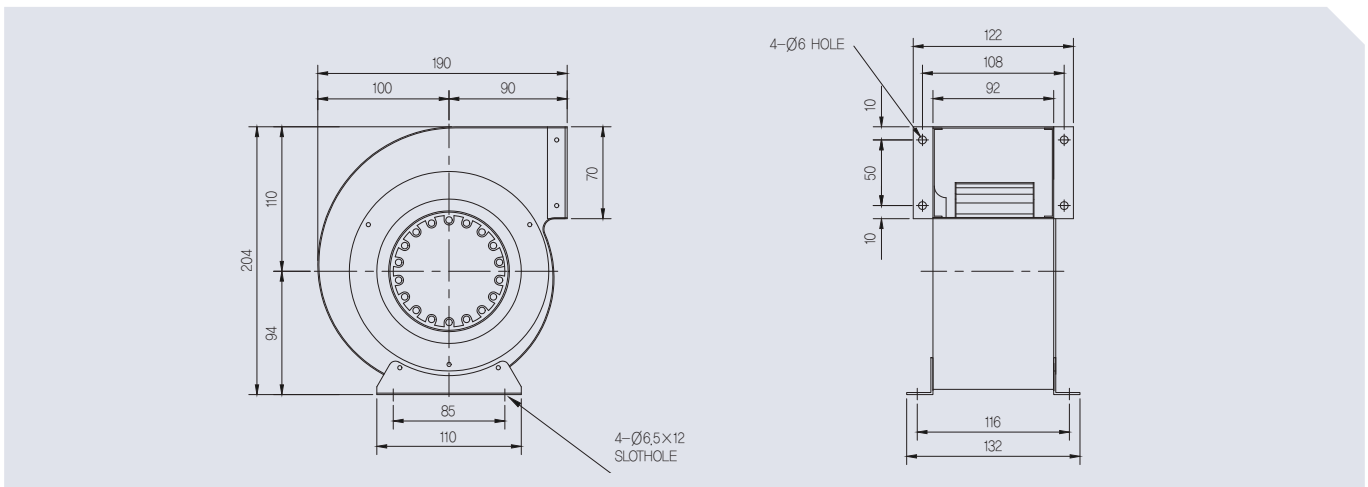

전 원			정압	풍량	소비전력	소비전류	회전속도
Phase	V	Hz	mmAq	CMM	W	A	RPM
φ 1	220	60Hz	39	4.3	105	0.48	1500
φ 1	220	50Hz	28	4.4	102	0.46	1550

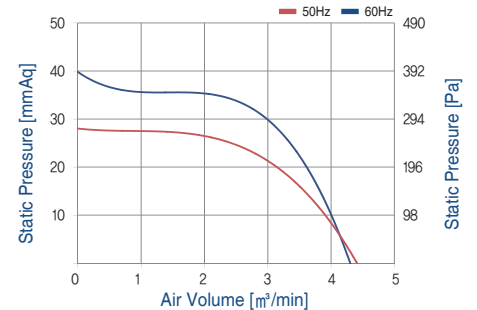

• AOS2S-145-60A

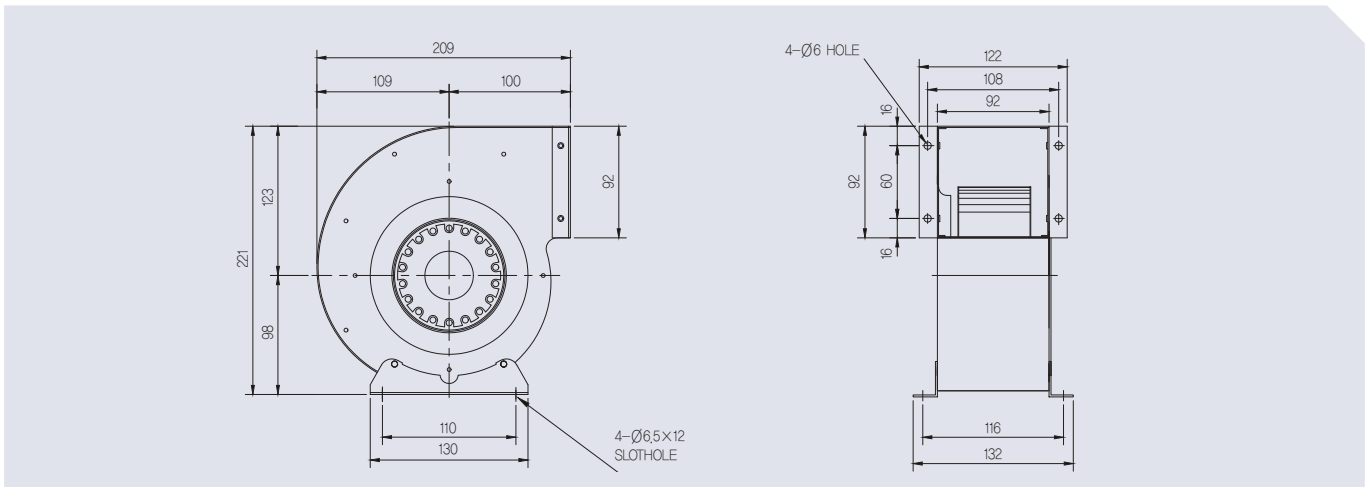

전 원			정압	풍량	소비전력	소비전류	회전속도
Phase	V	Hz	mmAq	CMM	W	A	RPM
φ 1	220	60Hz	57	5.9	155	0.71	1600
φ 1	220	50Hz	45	6.7	136	0.62	1780

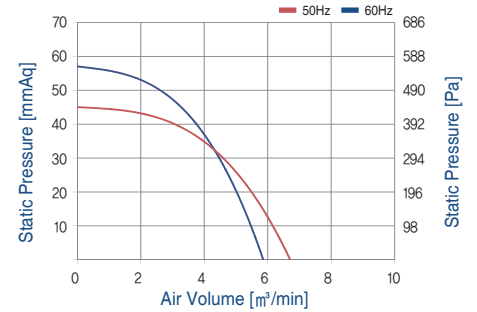

• AOS4S-145-60A

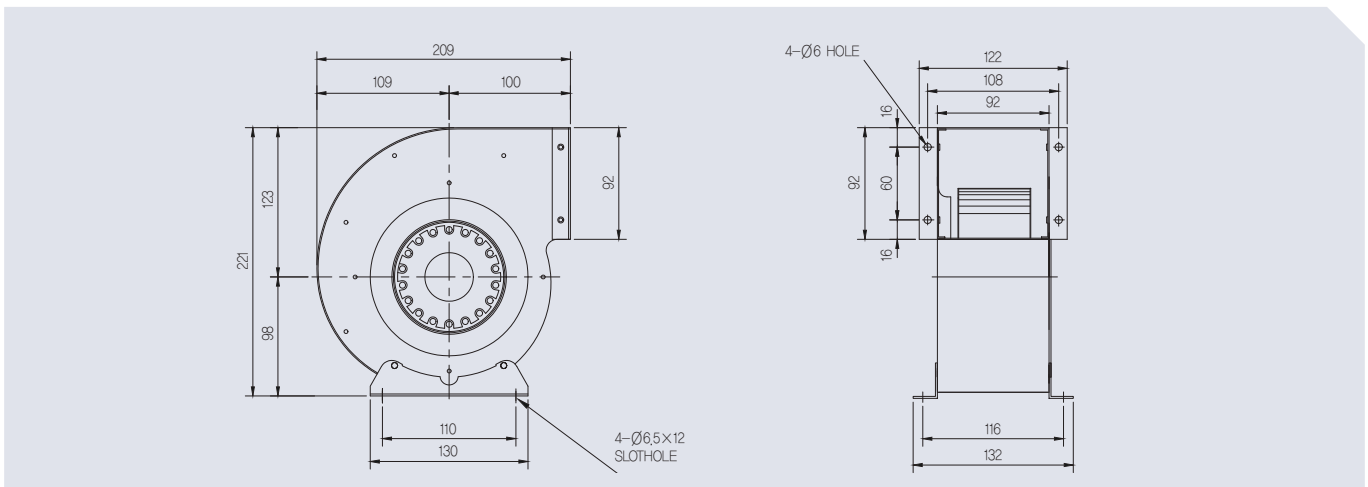

전 원			정압	풍량	소비전력	소비전류	회전속도
Phase	V	Hz	mmAq	CMM	W	A	RPM
φ 1	220	60Hz	40	6.5	140	0.5	1750
φ 1	220	50Hz	28	5.4	115	0.5	1450

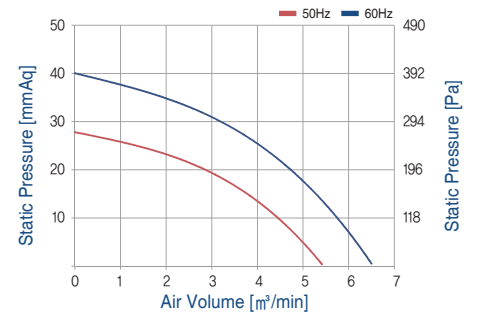

• AOS2S-160-60A

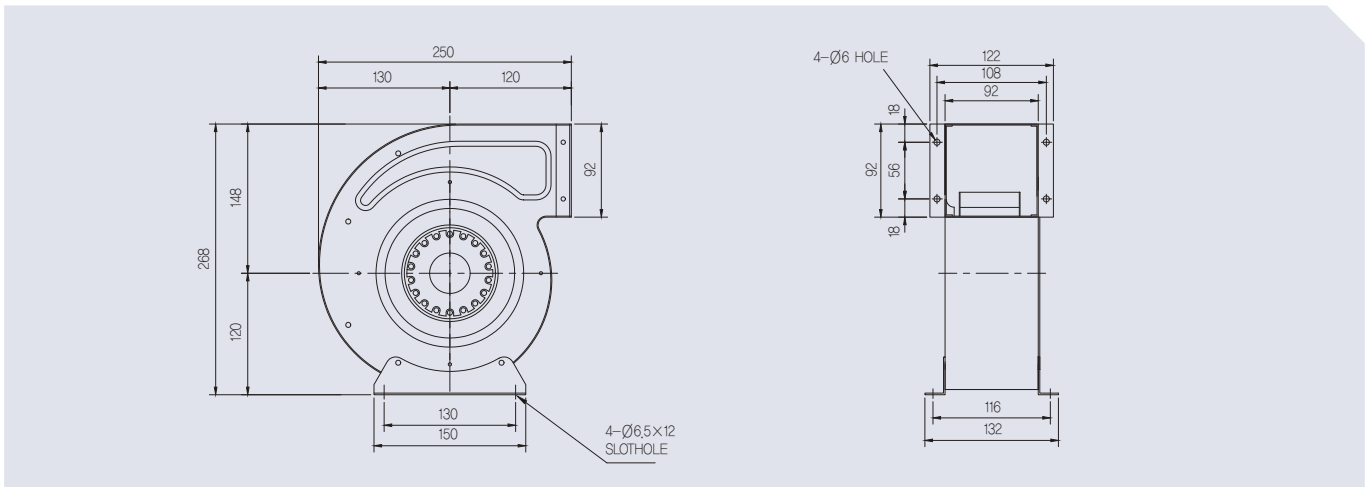

전 원			정압	풍량	소비전력	소비전류	회전속도
Phase	V	Hz	mmAq	CMM	W	A	RPM
φ 1	220	60Hz	72	8.0	260	1.2	2200
φ 1	220	50Hz	60	6.7	216	1.0	1850

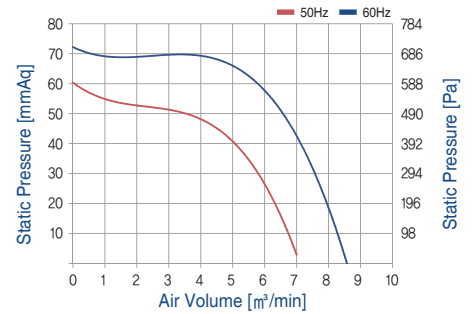

• AOS4S-160-60A

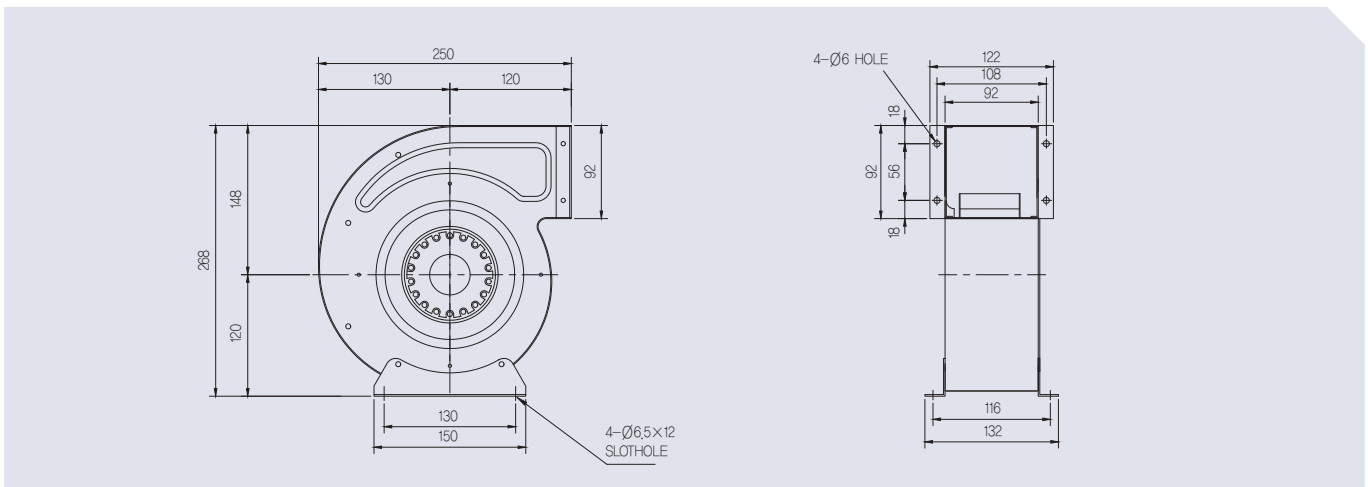

전 원			정압	풍량	소비전력	소비전류	회전속도
Phase	V	Hz	mmAq	CMM	W	A	RPM
φ 1	220	60Hz	23	7.5	82	0.4	1400
φ 1	220	50Hz	16	7.0	72	0.4	1300

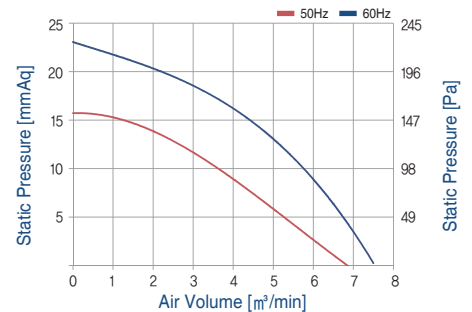

팬흡착결 다의 송풍기 (AC)

• AOS2S-180-75A

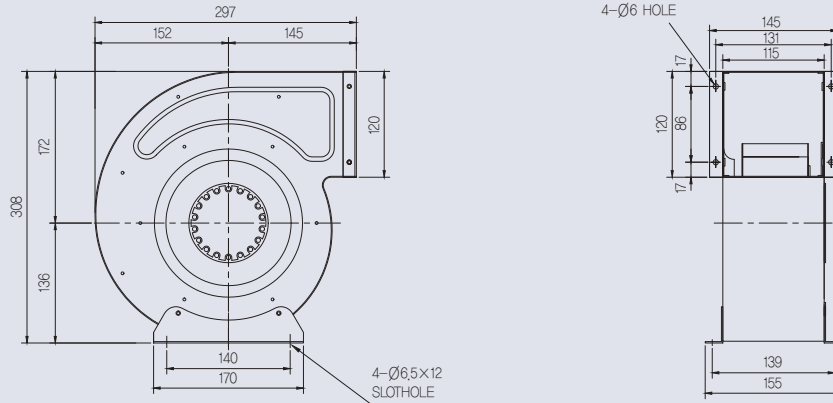

전 원			정압	풍량	소비전력	소비전류	회전속도
Phase	V	Hz	mmAq	CMM	W	A	RPM
φ 1	220	60Hz	95	10.8	330	1.5	2650
φ 1	220	50Hz	72	11.5	310	1.4	2080

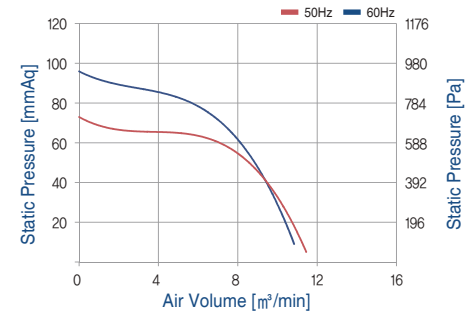

• AOS4S-180-75A

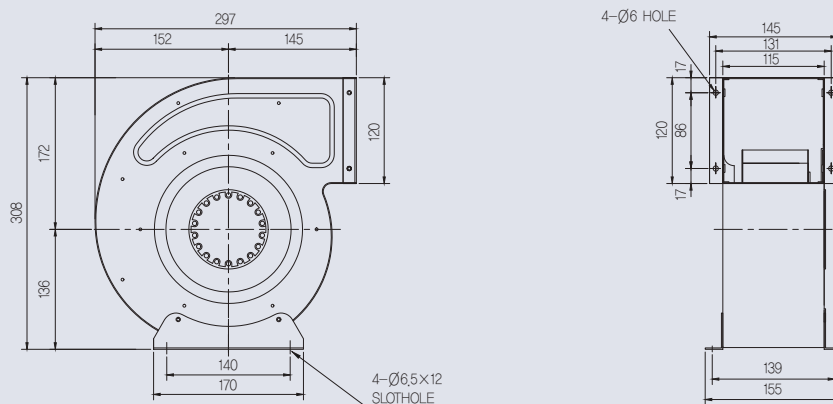

전 원			정압	풍량	소비전력	소비전류	회전속도
Phase	V	Hz	mmAq	CMM	W	A	RPM
φ 1	220	60Hz	32	10	140	0.7	1300
φ 1	220	50Hz	20	8.5	110	0.7	1250

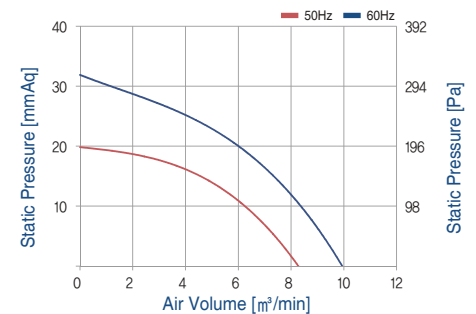

• AOS4S-180-90A

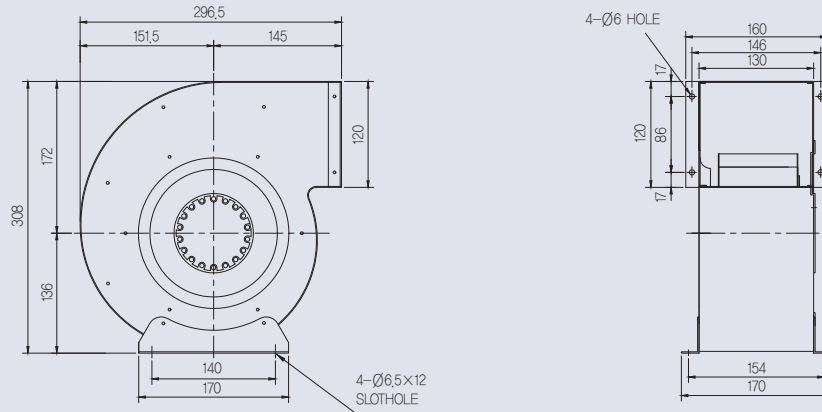

전 원			정압	풍량	소비전력	소비전류	회전속도
Phase	V	Hz	mmAq	CMM	W	A	RPM
φ 1	220	60Hz	32	15.5	190	0.8	1450
φ 1	220	50Hz	24	14.8	160	0.7	1200

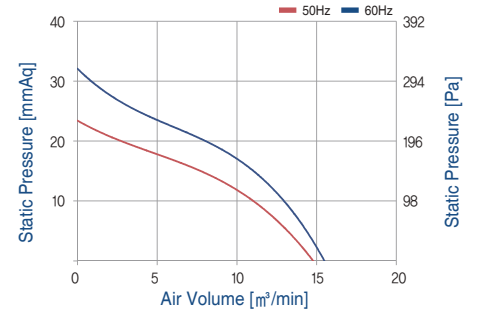

• AOS4S-200-100A

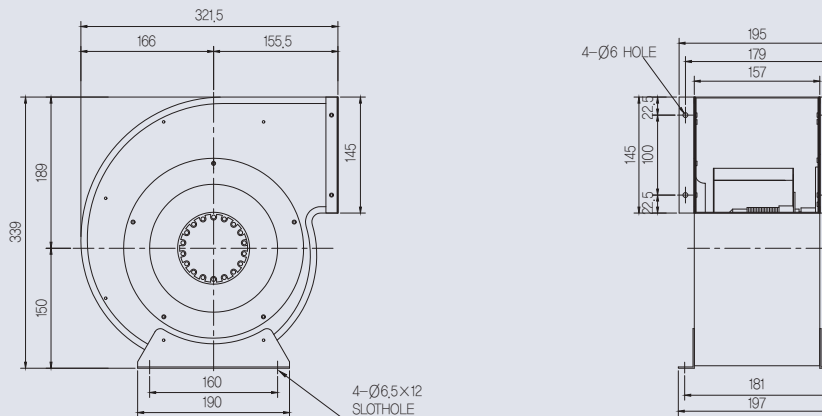

전 원			정압	풍량	소비전력	소비전류	회전속도
Phase	V	Hz	mmAq	CMM	W	A	RPM
φ 1	220	60Hz	34	16.0	280	1.6	1480
φ 1	220	50Hz	23	14.5	250	1.3	1300

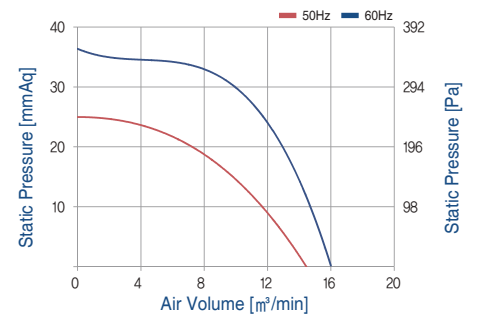

팬흡착결 디의 송풍기 (AC)