

# 아우터로터형 양흡직결 다익 송풍기

## OUTER ROTOR DOUBLE INLET DIRECT DRIVE CENTRIFUGAL FANS

### 제품 설명

- 전열 교환기 및 렌지 후드용 공기 이송장치, 전자장비 · 통신장비 냉각용에 적합
- 휠 일체형으로 소형화 및 경량화 실현, 협소한 장소에서의 설치 및 취급 용이
- 국제품질인증(CE마크) 획득을 통한 품질 확보
- 주파수와 관계없이 속도 제어 가능하며, 전식처리를 통한 제품 신뢰성 우수
- 풍량 대비 낮은 전기 소모량(고효율)으로 에너지 등급 우수
- 양흡입 구조로 다풍량 사용에 적합



### 제품 제원

MODEL	정압		풍량		상세 페이지
	mmAq	Pa	m <sup>3</sup> /min	ft <sup>3</sup> /min	
AOS2D-120-126A	40	392	6.0	212	121p
AOS2D-133-150A	60	588	13.3	469	
AOS4D-133-200A	23	225	7.5	265	122p
AOS2D-145-150A-1	32	314	7.5	265	
AOS2D-145-150A-2	54	529	11.0	388	123p
AOS4D-145-200A	18	176	11.5	406	
AOS2D-160-160A	78	764	16.0	565	124p
AOS4D-160-200A	26	255	23.5	830	
AOS4D-180-180A	32	314	28.0	988	125p

• AOS2D-120-126A

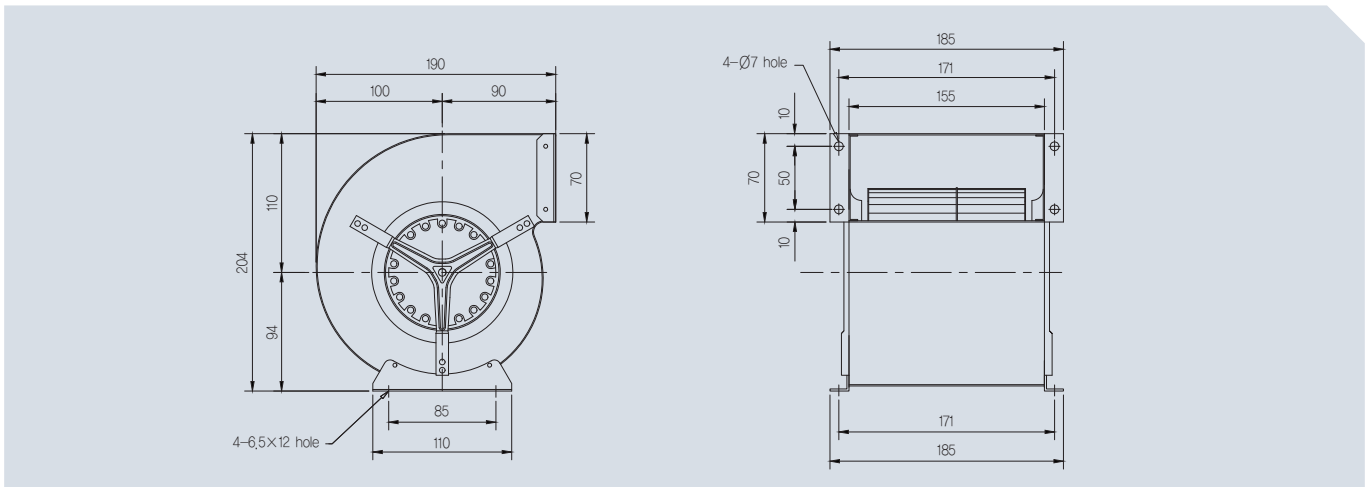

전 원			정압	풍량	소비전력	소비전류	회전속도
Phase	V	Hz	mmAq	CMM	W	A	RPM
φ 1	220	60Hz	40	6	110	0.5	1600
φ 1	220	50Hz	30	7	100	0.6	1650

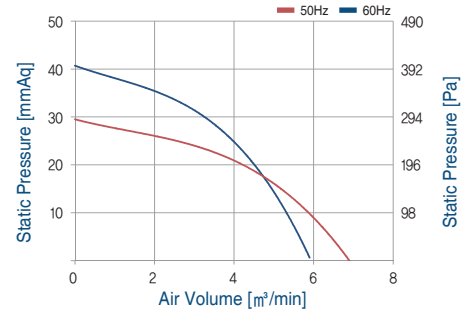

• AOS2D-133-150A

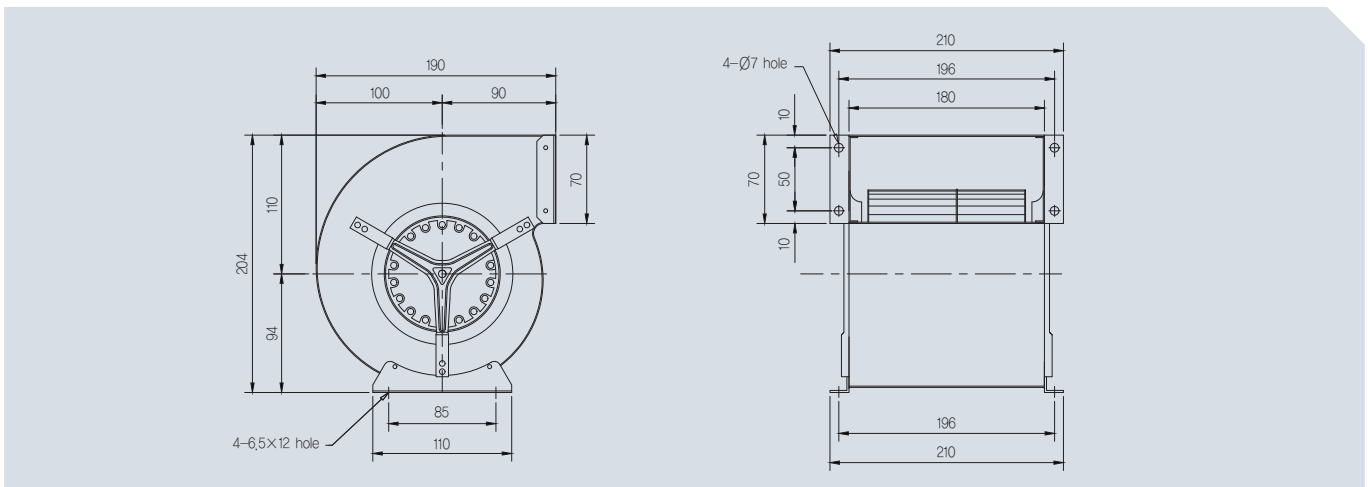

전 원			정압	풍량	소비전력	소비전류	회전속도
Phase	V	Hz	mmAq	CMM	W	A	RPM
φ 1	220	60Hz	60	13.3	190	0.9	2100
φ 1	220	50Hz	40	11.7	180	0.8	1700

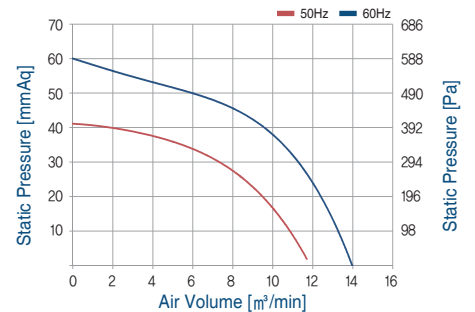

• AOS4D-133-200A

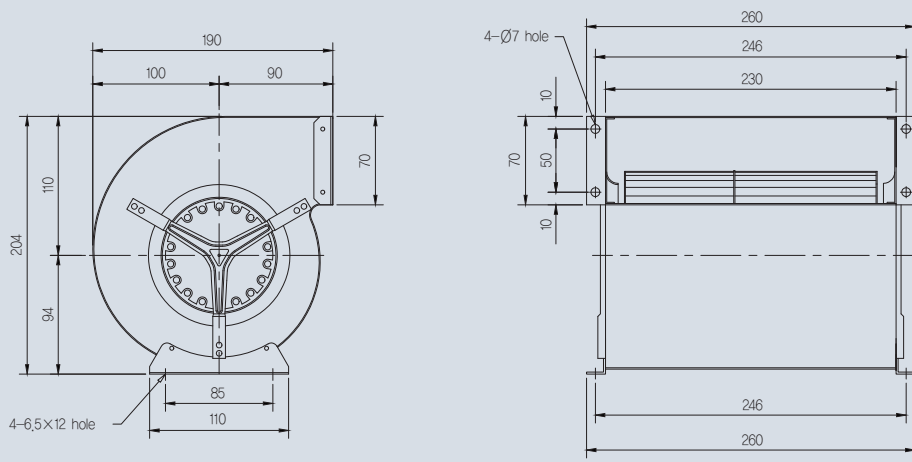

전 원			정압	풍량	소비전력	소비전류	회전속도
Phase	V	Hz	mmAq	CMM	W	A	RPM
φ 1	220	60Hz	23	7.5	80	0.4	1400
φ 1	220	50Hz	16	7.0	70	0.4	1300

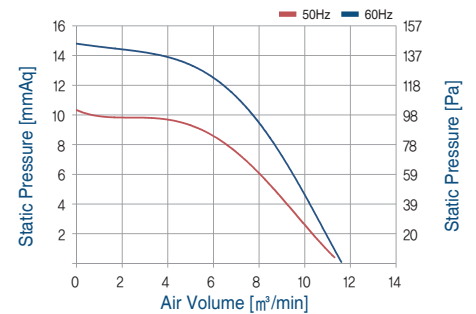

• AOS2D-145-150A-1

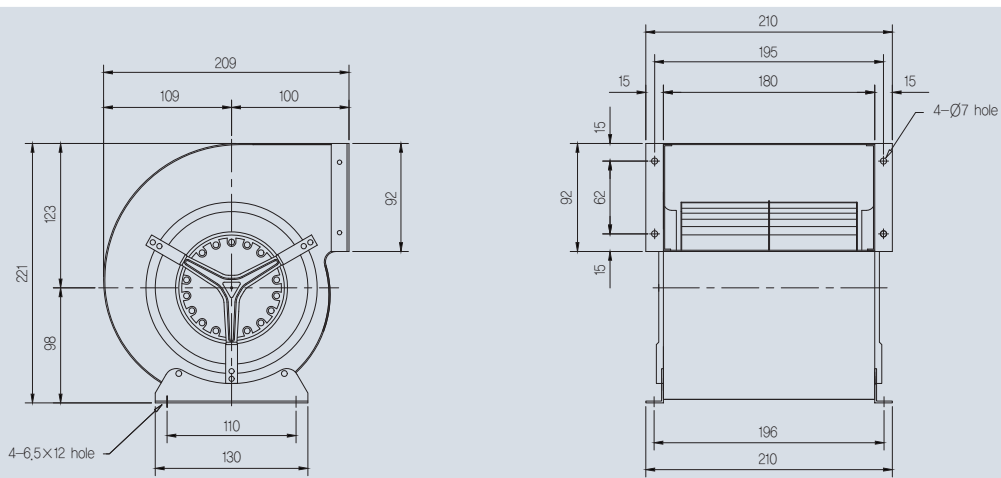

전 원			정압	풍량	소비전력	소비전류	회전속도
Phase	V	Hz	mmAq	CMM	W	A	RPM
φ 1	220	60Hz	58	8.2	207	1.0	2900
φ 1	220	50Hz	49	9.5	189	0.9	2700

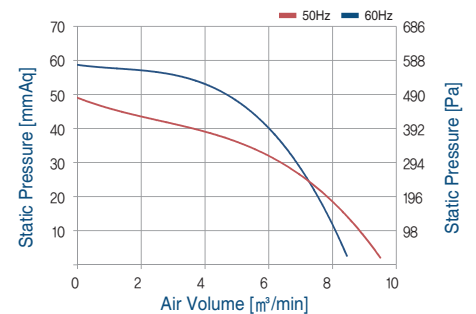

• AOS2D-145-150A-2

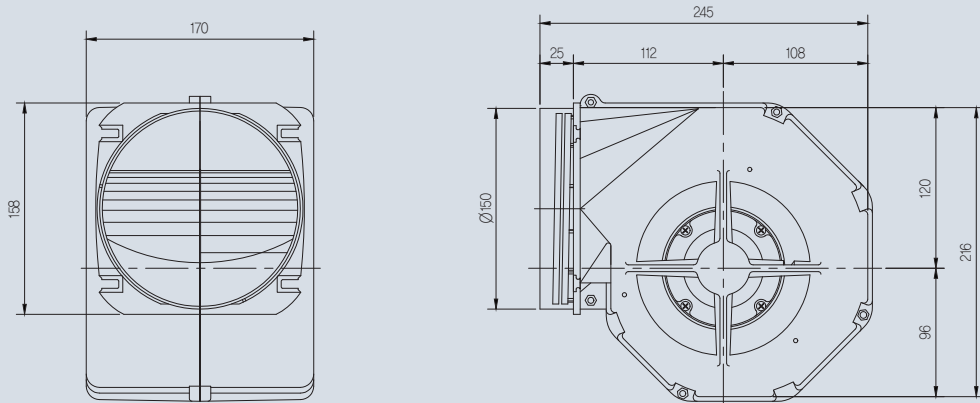

전 원			정압	풍량	소비전력	소비전류	회전속도
Phase	V	Hz	mmAq	CMM	W	A	RPM
φ 1	220	60Hz	54	11	200	0.9	1450
φ 1	220	50Hz	45	9	190	0.8	1200

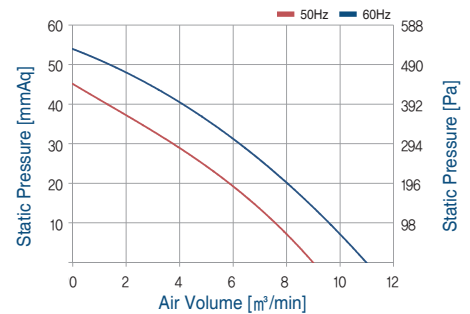

• AOS4D-145-200A

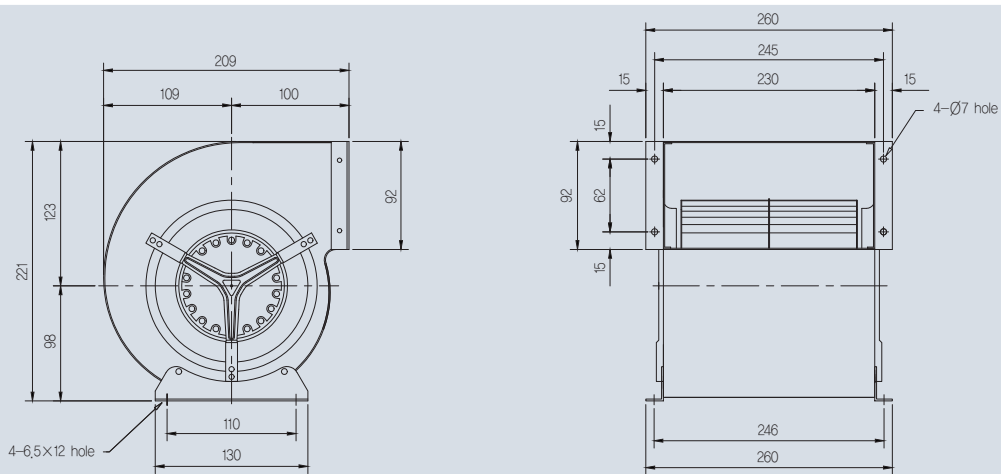

전 원			정압	풍량	소비전력	소비전류	회전속도
Phase	V	Hz	mmAq	CMM	W	A	RPM
φ 1	220	60Hz	18	11.5	90	0.5	910
φ 1	220	50Hz	14.5	12.0	80	0.4	980

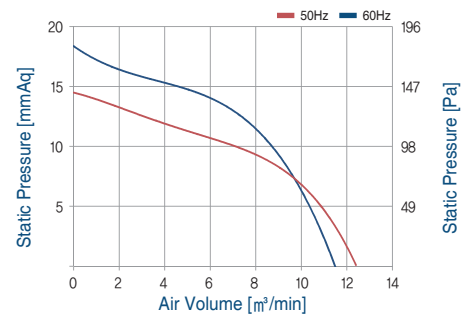

아우터로터형 양동작전

• AOS2D-160-160A

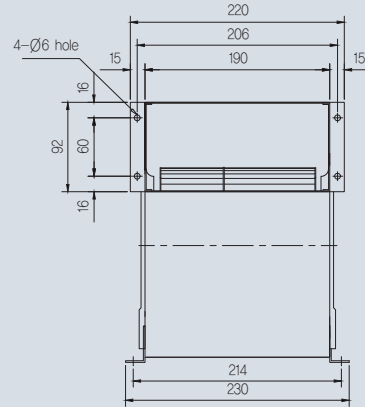
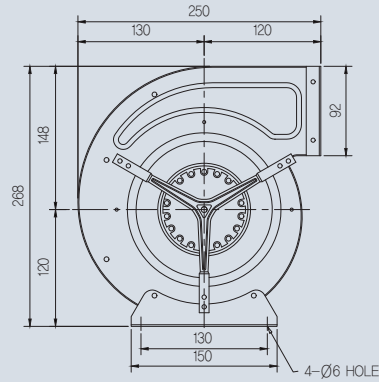

전 원			정압	풍량	소비전력	소비전류	회전속도
Phase	V	Hz	mmAq	CMM	W	A	RPM
φ 1	220	60Hz	78	16	290	1.4	1400
φ 1	220	50Hz	65	14	260	1.3	1500

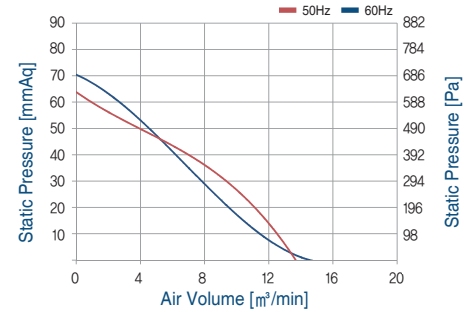

• AOS4D-160-200A

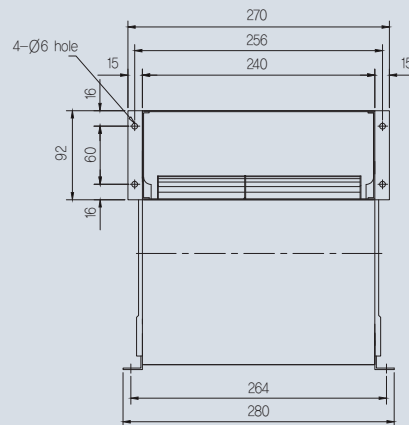
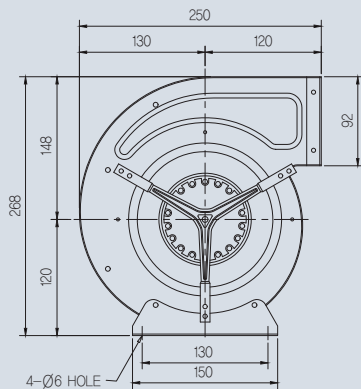

전 원			정압	풍량	소비전력	소비전류	회전속도
Phase	V	Hz	mmAq	CMM	W	A	RPM
φ 1	220	60Hz	26	23.5	280	1.2	1470
φ 1	220	50Hz	19	21.6	190	0.9	1370

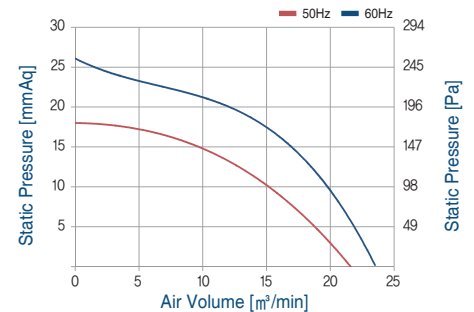

• AOS4D-180-180A

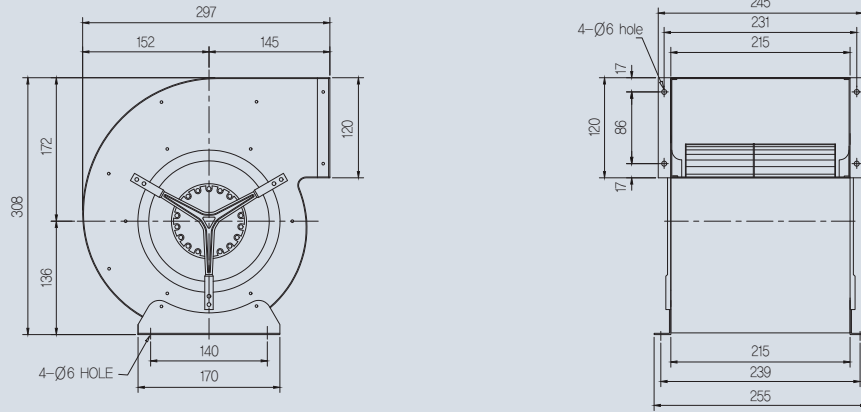

전 원			정압	풍량	소비전력	소비전류	회전속도
Phase	V	Hz	mmAq	CMM	W	A	RPM
φ1	220	60Hz	32	28	260	1.5	1300
φ1	220	50Hz	23	26	220	1.0	1250

